

MOMA STONE WASHSTAND

(FROM THE ABBY ALDRICH ROCKEFELLER SCULPTURE GARDEN; NEW YORK, NY)

These beautifully polished stone tops were carved from large paving stones salvaged from the Museum of Modern Art's Abby Aldrich Rockefeller Sculpture Garden. Designed by the acclaimed American architect Philip Johnson, the garden was opened to the public with the opening of the east wing and garden wing in 1964. Steeped in history, the stone has gracefully supported the weight of sculptures created by such artists as Lachaise, Matisse, Oldenburg, and Rodin. The stone was acquired in the historic demolition of the garden to make way for the construction of the new Museum of Modern Art.

*Please note that the MoMA marble washstand is priced separately from the hardware and legs. Please call our Franklin Street location for more information regarding washstand pricing.



MoMA

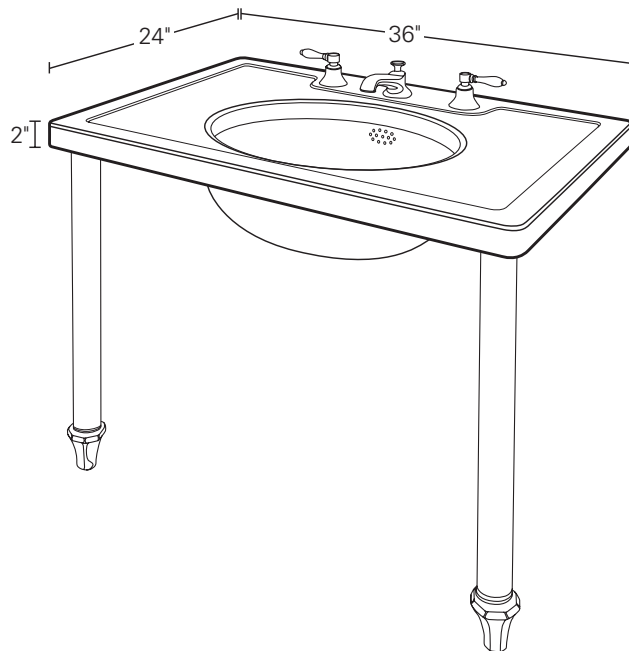

A view of the garden taken by Ansel Adams

REF# UA10 SV

*Please contact our Franklin Street Showroom for more information.