

## Assembly Instructions for Floor Model Rolling Rack (UA0018 RC)

When you receive your rolling rack, please read these instructions before unwrapping parts.

If you have purchased one (1) rolling rack, all parts will be labeled inside the bubble wrap to denote either right or left side of the rolling rack.

If you have purchased more than one rolling rack, all parts will be labeled outside the bubble wrap to denote which parts belong to which rolling rack, after separating each set of parts for each rack, all parts will be labeled inside the bubble wrap to denote right or left side.

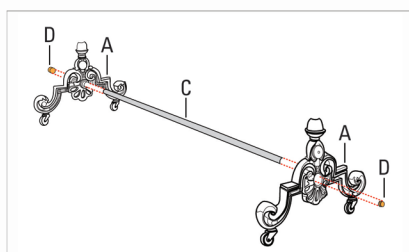
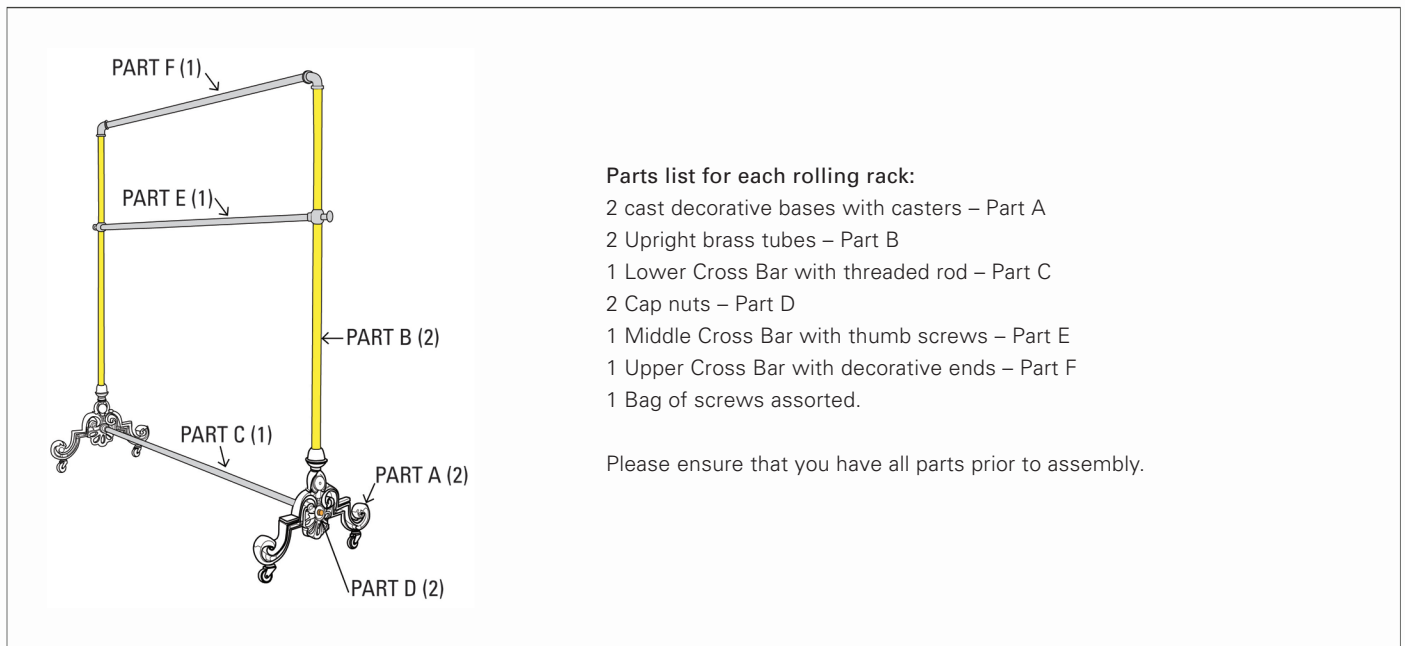

**STEP 1:** Place threaded rod from part C through hole in side of part A – loosely attach cap nut (part D) to outside end of threaded rod.

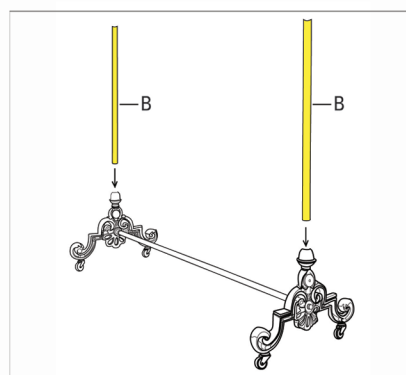

**STEP 2:** Insert Upright Tube (part B) into hole at top of foot (part A). Fix in place with provided set screw, long thread.

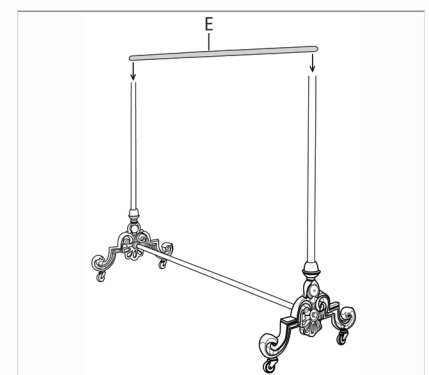

**STEP 3:** Open thumb screws on Middle Cross Bar (part E) so that holes are completely free of obstruction and gently slide Middle Cross Bar over both uprights at the same time, tighten thumb screws to hold in place.

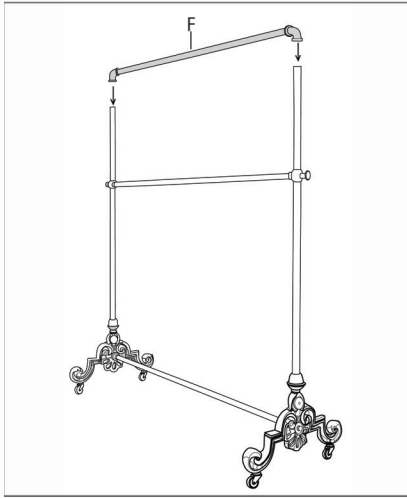

**STEP 4:** Insert decorative ends of Upper Cross Bar (part F) into top of two Upright Tubes (part B). Fix in place with provided set screws (short thread).

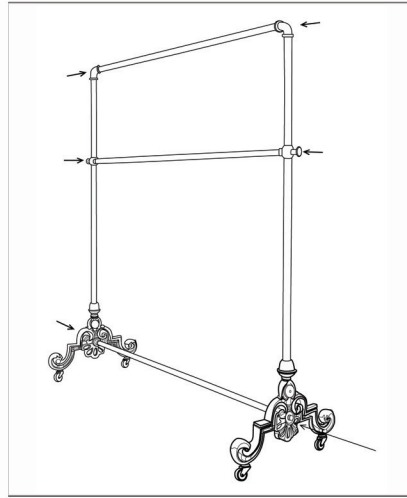

**STEP 5:** Tighten both Cap Nuts (part D), and all set screws.

Note: Middle Cross Bar should slide easily up and down Uprights when thumb screws are loosened. Repeated movement of this cross bar can mar some finishes, use caution.